



Operator's Manual

MANLINK-1 REV H 08/20

200L / 300L / 400L / 800 / 1000L Slimline Series
Linkage Sprayer





Introduction

Silvan is an Australian owned company specialising in supply of crop protection equipment to primary producers. A leader in the design of agricultural sprayers, the company was established in 1962 and has grown to become the largest manufacturer and supplier of crop protection equipment in Australia.

Silvan's reputation for quality products backed by quality service is something of which we are extremely proud. Your investment in a Silvan sprayer is an investment in quality.

This manual covers the 200L, 300L, 400L, 800L and 1000L Slimline Series linkage sprayers, which have been designed and manufactured to provide a high standard of performance and safety and incorporate many innovative features. To ensure continued efficient performance and safe operation of your sprayer, you need to read this manual thoroughly and fully familiarise yourself with all aspects of the sprayer's operation, maintenance and safety procedures.

Now that you are a proud Silvan owner, all our services and dealer support is available to you should you need them. We assure you of our best attention at all times.

No liability can be accepted for any inaccuracies or omissions in this publication, although due care has been taken to make it as complete and accurate as possible.

The information, illustrations and technical data were considered to be correct at the time of preparation.

In accordance with our policy of continuous development, Silvan Australia Pty. Ltd. reserves the right to make changes at any time without notice.



Contents

Introduction	1
Contents	2
Sprayer Details	2
New Product Warranty Policy.	3
Safety Information	4
Decals Position & Description	5
Specifications	6,7
Operation	8-12
Sprayer Calibration	13-16
Maintenance	17,18
Troubleshooting	19
Notes	20

YOUR SPRAYER DETAILS

Record the details of your sprayer here for future reference when discussing service with your Silvan dealer, ordering parts or making a warranty claim.

SERIAL NUMBER _____

MODEL _____

DATE OF DELIVERY _____

SELLING DEALER _____

ADDRESS _____

TELEPHONE NO. _____

INSTALLED BY _____



Warranty

Silvan Australia Pty. Ltd. builds equipment to a high level of specification using components from quality suppliers. The following information is provided to assist you with any repairs required within the warranty period. All warranty repairs on Silvan products are carried out by Silvan dealers. If any warranty repairs are required on Silvan products, it is recommended that the product be returned to the place of purchase. It is good practice to keep a record of equipment maintenance both during and after the warranty period.

The warranty policy below explains the extent and limitations of your Warranty coverage on Silvan Products.

This warranty is the only warranty applicable to Silvan new products ('Products') and, to the maximum extent permitted by law, is expressly in lieu of any other conditions or warranties expressed or implied in relation to the Products.

Subject only to legislative obligations to the contrary, Silvan shall not be liable for incidental or consequential damage resulting from ownership or use of a Product. Silvan does not authorize any person to create for it any other obligation or liability in connection with these products.

Silvan warrants its authorised Dealer, who in turn warrants the original purchaser (owner) of each new Silvan product that it will repair or replace the product, or, pay the cost of repair or replacement, as determined by Silvan without charge for labour or any defective or malfunctioning parts in accordance with the warranty limitations and adjustment schedule below.

The warranty period begins on the date the product is delivered to the first retail purchaser for a period of 12 months.

This Warranty Covers: Only conditions resulting directly from defects in workmanship or material under normal use and service.

Warranty Exclusions: The Warranty does not cover:

- Conditions resulting from misuse, use of incompatible chemicals, exceeding machine specifications including overloading, impact damage, negligence, accidental damage or failure to perform recommended maintenance services.
- Any product which has been repaired by other than an authorised Silvan service outlet in a way which, in the sole and absolute judgement of Silvan, adversely affect its performance or reliability.
- The replacement of maintenance items such as diaphragms, batteries, V belts and ground engaging components, etc.
- Loss of time, inconvenience, loss of use of the product, liability to third parties or any other consequential damages.
- Incidental costs associated with a warranty repair including any travel costs, out of hour's labour charges, cleaning costs, transportation costs, freight costs or any communication costs.
- The repair of a defective product qualifying under this warranty will be performed by any authorised Silvan service outlet within a reasonable time following the delivery of the product, at the cost of the owner, to the service outlet's place of business. The product will be repaired or replaced, using new parts supplied by Silvan. Silvan, at its absolute discretion, may choose to pay the cost of replacement or repair of the product.

The owner is responsible for the performance of regular maintenance services as specified in the Owner/Operator Manual applicable to the product. Failure to carry out regular maintenance may invalidate warranty.

Safety Information



Before operating the sprayer, read the following safety instructions.

Failure to comply with these warnings may result in serious injury or death.

This sprayer is designed and manufactured solely for the purpose of applying agricultural chemicals to crops. Under no circumstances should it be used for any other purpose.

- Before using the sprayer, carefully read and ensure you understand the contents of this manual and any other manual supplied with the sprayer.
- Before operating the sprayer, read all the safety warnings, which are carried on various parts of the machine. Refer to the next page for a location diagram and the wording of these warnings.
- Never allow an inadequately trained person to attach or operate the sprayer.
- Do not operate the sprayer whilst wearing loose clothing, unrestrained long hair, jewellery or anything which could become entangled in rotating components or limit your vision.
- Wear ear protection when operating the sprayer on a tractor which is not fitted with a sound proofed cabin.
- Ensure the linkage capacity of the tractor is suitable for the loaded mass of the sprayer. Refer to the tractor operator's manual for safe working loads and relevant tractor safety instructions.
- Exercise extreme care when operating in hilly or uneven terrain to ensure adequate stability. Refer also to the tractor manufacturer's operating and safety instructions.
- Do not operate the pump at speeds greater than 540 PTO rpm and less than 400rpm.
- Do not operate the sprayer without all of the tractor and sprayer safety shields in place. Carefully check that PTO and driveline shields are correctly installed.
- Stop the tractor PTO, apply the parking brake and switch off the tractor engine before approaching the sprayer and performing any work on it.
- Disconnect the PTO shaft at the tractor and ensure the sprayer is properly supported before performing any maintenance work.
- **Before use of any chemicals** refer to the chemical manufacturer's label and safety instructions for safe handling procedures and correct method of use. Always use the recommended personal protective clothing and equipment.
- Always wear gloves when removing and cleaning filters.
- Dispose of empty chemical containers in accordance with the instructions supplied by the chemical manufacturer.
- Ensure that all operators and associated personnel are familiar with the legal regulations and codes of practice that apply to the safe use and storage of spray chemicals.
- Ensure all bystanders are at a safe distance from the machine.
- Do not use flammable liquids or gases in the sprayer.

Safety Information

 The location and wording of the safety decals fitted to Silvan linkage sprayers is shown below. It is important that all operators read and follow the information on all safety decals before operating the sprayer. **Failure to comply with these warnings could result in serious injury or death.** Safety decals should be kept clean and legible at all times. If any decals are missing or unreadable they should be replaced by ordering new decals from your Silvan dealer using the part numbers shown below.



WARNING

BEFORE APPLYING CHEMICALS WITH THIS SPRAYER READ THE LABEL OF THE CHEMICAL MANUFACTURER OR SUPPLIER FOR THE RECOMMENDED PERSONAL PROTECTIVE EQUIPMENT AND USE IT AS RECOMMENDED.

READ THE OPERATORS INSTRUCTION MANUAL BEFORE ATTACHING OR USING THIS PRODUCT.

REFER TO YOUR VEHICLES OPERATION MANUAL FOR THE MAXIMUM LOAD LIMITS AND OPERATING PROCEDURES.

DO NOT EXCEED SPECIFIED SAFE LOAD CARRY AND TOWING CAPACITIES. STABILITY OF THE VEHICLE CAN BE AFFECTED BY THE ATTACHMENT'S WEIGHT AND WEIGHT MOVEMENT.

REDUCE THE SPEED OF THE VEHICLE WHEN CARRYING AN ATTACHMENT AND ALLOW GREATER DISTANCE FOR BRAKING.

DO NOT RIDE ON THIS MACHINE.

DANGER

DISCONNECT TRACTOR BEFORE ADJUSTING, SERVICING, CLEANING OR INSPECTING SPRAYER.

KEEP CLEAR OF OPERATING MACHINERY.

DO NOT OPERATE WITHOUT GUARDS OR SHIELD IN PLACE. FAILURE TO HEED THESE WARNINGS COULD RESULT IN SEVERE PERSONAL INJURY OR DEATH.

IMPORTANT

P.T.O SPEED MUST NOT EXCEED 540 R.P.M & ENSURE P.T.O SHAFT IS CORRECT LENGTH.

EACH DAY: GREASE TELESCOPIC TUBE ON P.T.O SHAFT. GREASE UNIVERSAL JOINTS, CLEAN SUCTION STRAINER, CHECK PUMP OIL LEVEL, FLUSH OUT PUMP WITH WATER AFTER USE. FOR GENERAL MAINTENANCE, REFER TO THE INSTRUCTION MANUAL.

DEC 101213P

Part Number DEC101213P

DANGER



ROTATING DRIVELINE CONTACT CAN CAUSE DEATH KEEP AWAY!

DO NOT OPERATE WITHOUT-

- ALL DRIVELINE GUARDS, TRACTOR AND EQUIPMENT SHIELDS IN PLACE
- DRIVELINES SECURELY ATTACHED AT BOTH ENDS
- DRIVELINE GUARDS THAT TURN FREELY ON DRIVELINE

USA

Part Number US4

BARE-GO TRIMMING IMPLEMENT PTO SHAFT TO SUIT YOUR TRACTOR

NOTE: End thread from over length shafts (or varied telescopic tubes) can destroy your tractors internal PTO drive or implement shafts and gears, voiding your machine warranty.

- 1) Measure groove to groove distance from implement shaft to tractor shaft with implement in short/flat position. NOTE: Length will vary as implement is raised or lowered
- 2) Remove safety guard from new shaft and measure length between shaft lock buttons or clamp bolts with shaft in closed position.
- 3) Required length of shaft is groove to groove length (step 1) less a minimum of 16mm (5") to allow for disconnection from tractor and prevent end thrust damage. If shaft is shorter than this, ensure the size of telescopic tubes overlap.
- 4) Assess to cut off shaft, length of new shaft (step 2) less groove to groove measurement (step 3) plus 16mm (5"). Cut this amount of both inner and outer drive tubes. Remove burrs and grease tubes.

E.g. New shaft	1150mm (45")
Less groove to groove requirement plus telescopic tubes	- 800mm (31")
Allowance to cut off	= 350mm (13")

Match relevant only

Repeat your own measurements.

Part Number INS142
INSTRUCTION BOOKLET
Attached to PTO shaft

Specifications

Pumps

Positive displacement oil-backed diaphragm pump of varying size depending on sprayer specification. Output at 540 PTO rpm and maximum operating pressure as shown below.

Pump Model	Output l/min	Pressure Bar	psi	No.of Diaphragms
BP 20/15	19	15	215	2
BP 60/20	58	20	290	2
BP 75/20	68	20	290	3
BP 125/20	117	20	290	3

Note Maximum operating speed 540 rpm.
Minimum operating speed 400 rpm.

This pump has been designed and constructed solely to pump agricultural liquid chemicals, normally used for pest, weed and fungus control.

It must not be used to pump:

- Liquids with a density and viscosity greater than water.
- Chemical products if the compatibility with the materials of the pump is not known.
- Sea water or other salty concentrations.
- Water with a temperature above 40°C and less than 5°C.
- Any type of varnish.
- Solvents and thinners for any type of varnish.
- Any type of fuel or lubricant.
- Liquids containing granules or floating solid parts.
- Chlorine.
- For special liquids please contact Silvan service department.

Pump Identification

The following data is found on the pump name plate:

1. Pump Type
2. Maximum Delivery (at 0 Bar)
3. Delivery at Maximum Pressure
4. Maximum Pressure Permitted in Pump
5. Maximum RPM
6. Manufacturer's Serial No

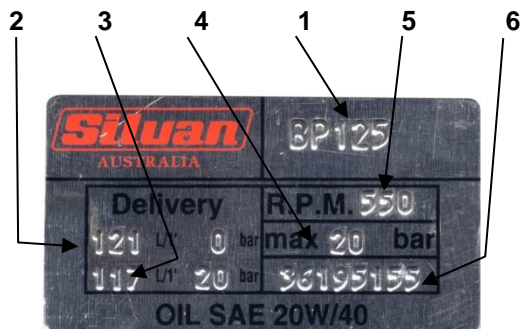

Component Identification

Refer to the following diagrams for the position of the various components relating to your pump.

1. Mounting Base
2. Oil Reservoir Accumulator
3. Pump Shaft
4. Pressure
5. Pump Head
6. Inlet Valve Cap
7. Inlet Hose Barb
8. Inlet Crankcase
9. Inlet Manifold
10. Delivery Manifold
11. Oil Level Cap
12. Delivery Coupling
13. Oil Cap
14. PTO Safety Shield
15. Delivery Coupling
16. Delivery Coupling
17. Oil Cap

BP60/20

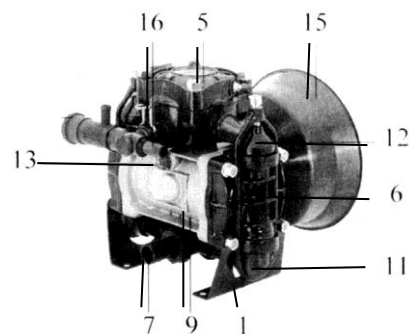

BP75/20

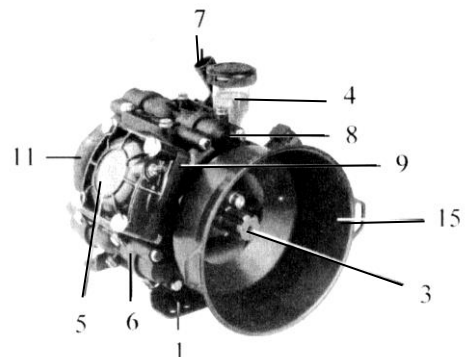

BP125/20

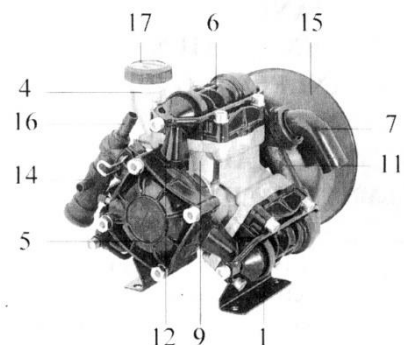

Specifications

Tank

Slimline designed tank constructed from Polyuff impact resistant polyethylene.

Capacity 200 / 300 / 400 / 800 / 1000 litres with calibrated external level indicator.

255mm diameter screw down lid with basket strainer. Suction filter with shut off valve.

Drive

540 rpm PTO shaft with safety shields.

Controls

Screw type pressure regulator.

Glycerine filled pressure gauge. Dual scale on some models.

2 / 3 or 4 manual tap outlets.

Continuous bypass agitation.

Filtration

Two stage with removable elements on all units. Standard mesh shown. Alternatives available.

- | | |
|--|----------|
| 1) Tank lid strainer | 18 mesh. |
| 2) Suction line filter (blue).
Boom if fitted | 50 mesh |
| 3) Nozzle strainers | 50 mesh. |

Frame and Hitch

Heavy duty galvanized steel construction.

Reversible Category 1 & 2 linkage pins on 200, 300, 400, 800 litre models.

Cat 2 pins only on 800 litre Heavy Duty and 1000 litre models.

Factory or Dealer fitment options.

Note: not all options will fit all models.

Electric Controls

Electric on/off 3 section solenoid control

Electric valve controls, 3 section with master valve and electric pressure adjust in cab (800 / 1000 litre models)

Hose Reels

Economy Hose Reel. 20 and 30m hose options with several spraygun types

Foam Marker

14 litre foam marker (single side)

16 litre foam marker (double side)

Flush Tank

70 litre flush tank for filter, pump, spraylines etc (1000L only)

Silmix Chemical Hopper

30 litre chemical induction hopper for 800L / 1000L only

Auto Spray Rate Controller

Maintains application rate when there are variations in ground speed.

Spray Booms

Field Boom 6m, 8m or 10m

Galvanized steel truss

Three section manual horizontal fold

Spring loaded break back.

BP 60/20 pump required for 10m boom

Devil Boom 6m, 8m, 10m, 12m, 14m, 15m

Galvanised steel truss

Hydraulic fold

Spring loaded break back

Hydraulic lift (optional)

Airbag suspension (optional)

Note: 12m, 14m & 15m Devil boom only available on 800 & 1000L sprayers (800L sprayers require heavy duty frame upgrade)

Vine Boom 8 or 10 Jet

Adjustable telescopic arms

Adjustable brass nozzles

Olive Boom 9 Jet

Adjustable sliding arm

Adjustable brass nozzles

Under Vine Boom

Galvanised frame

Telescopic sliding adjustment for boom width and height.

Double swivel nozzle holders can be fitted with standard fan or off centre nozzles.

Dimensions and Weights

Mass (**kg**) with a full tank and no boom or accessories fitted.

	L(mm)	W(mm)	H(mm)	kg
200 litre	920	740	920	260
300 Litre	1105	740	1070	370
400 Litre	1105	740	1310	475
800 Litre	1330	980	1370	920
1000 Litre	1650	1250	1370	1170

Width of Sprayer with boom folded for transport

<i>Field Boom</i>	6m	2.067m
	8m	2.067m
	10m	2.067m
<i>Devil Boom</i>	6m	2.120m
	8m	2.120m
	10m	2.120m
	12m	2.120m
	14m	2.120m
	15m	2.120m

Operation

Attaching to the Tractor

Most Silvan linkage sprayers are equipped to fit tractors with either Category 1 or 2 linkages (800L HD & 1000L Cat 2 only). The inner end of each lower linkage pin is Category 1 and the outer end is Category 2. The lower holes in the top connection plates are Category 1 and the upper holes are Category 2.

Remove the PTO shaft from the sprayer by depressing the locking pin. Lower the tractor linkage and attach it to the sprayer's lower hitch pins of the appropriate category, then connect the top link using the tractor's top link pin. Secure the linkage arms and top link pin with the tractor's lynch pins. Raise the tractor linkage to the desired spraying height and level the sprayer by adjusting the length of the top link and by using the lower arm leveling mechanism.

Clean and grease the splines on the tractor and sprayer PTO stub shafts and install the PTO shaft making sure that the spring loaded locking pins engage in the interference grooves of both stub shafts. Ensure that the PTO shaft guard chains, if fitted, are attached to the sprayer and tractor.

PTO Shaft Length (Refer to instruction booklet INS42 attached to PTO shaft)

Note: Upon delivery of a new PTO driven sprayer, it is the selling dealer's responsibility to install and set the PTO driveshaft to the correct length, as part of the installation service. The following information is provided for reference.

Set the linkage height so that the ends of the two shafts are at their closest distance. Install the PTO shaft making sure that there is at least 25mm of telescopic travel remaining between the male and female sections. Raise and lower the sprayer to check that the telescopic tubes of the PTO overlap by approximately 1/3rd of their length, and not less than 150mm, in all operating positions.

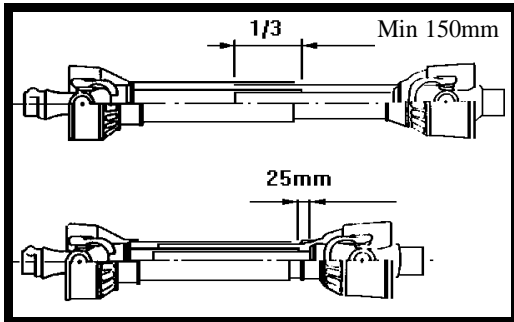

If the PTO shaft must be shortened, cut equal amounts from both male and female shafts and safety covers. Carefully remove all burrs then clean and lubricate before reassembling.

Pump

1. Check the oil level while the pump is standing still and sitting horizontally. The oil must reach the level indicated on the sight glass (BP20/15, BP125/20, BP75/20 fig 1) or be visible on the oil level plug (BP60/20 fig 2). Top up with SAE 20W/40 oil if necessary.

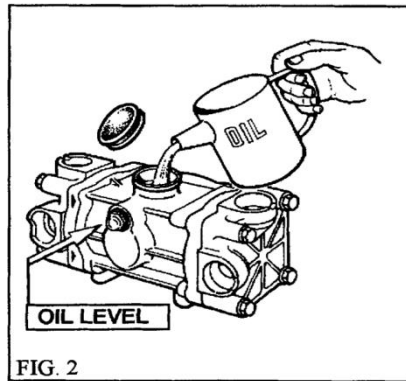
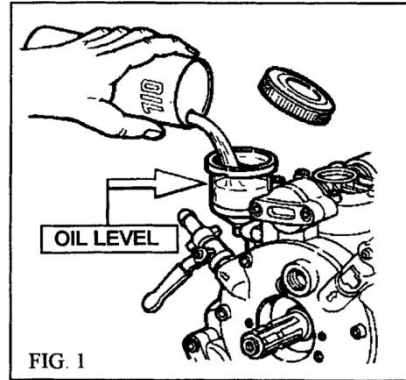

2. Adjust the air pressure in the pressure accumulator if fitted in accordance with the operating pressure used to spray. Adjust according to Table A below. The pressure can be measured using a reliable bicycle fork pressure gauge. (Note a car tyre or bicycle tyre gauge lets too much air escape to be accurate).

Surge air pressure	Bar	2-5	5-10	10-20	20-50
Spraying pressure	p.s.i.	29-73	73-145	145-290	290-725
Surge air pressure	Bar	2	2-5	5-7	7
	p.s.i.	29	29-73	73-102	102

Alternatively add air to the accumulator, to just above the required pressure (using a car tyre inflator is OK) start the pump and adjust the pressure regulator to the required spraying pressure then bleed air from the accumulator until the pulsations of the pump are least noticeable, at this point the needle on the pressure gauge will be at its steadiest.

Operation

Optional Flush Tank (1000 litre)

To Fill The Flush Tank:

1. Remove the cap (top left hand side of the Flush Tank)
2. Place hose in the tank opening
3. Fill the tank with water (70L)
4. Replace the cap after filling the tank.



To Flush The System:

1. After Spaying, Disengage the PTO.
2. Turn the ball valve from the "Main Tank" (12 o'clock) to the "Flush Tank" (6 o'clock) position
3. Turn the unit back on to flush the system (With the **Section Valves** turned **ON**).

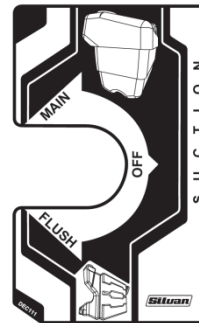
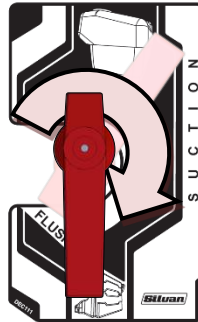

To Clean The Filter:

1. Disengage the PTO
2. Turn the ball valve to the "Off" position (3 o'clock)
3. Unscrew the filter nut & remove the filter bowl
4. Clean the filter
5. Secure the filter & filter bowl in position

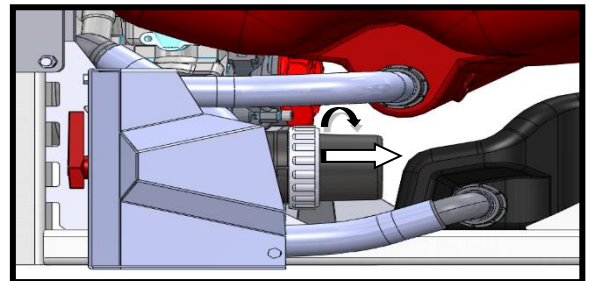
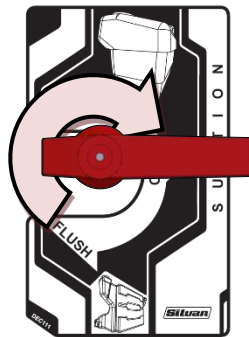

To Drain The Main Tank:

1. Disengage the PTO
2. Turn the ball valve to the "Off" position (3 o'clock)
3. Unscrew the filter nut & remove the filter bowl
4. Turn the ball valve to the "Main Tank" position to drain the main tank

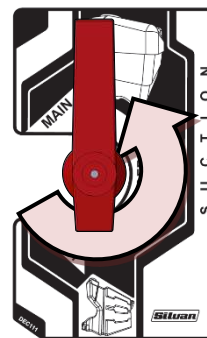
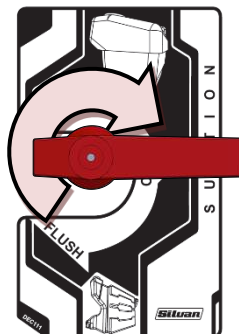

To Drain The Flush Tank:

1. Disengage the PTO
2. Walk around to the right hand side of the machine
3. Remove the end cap
4. Allow water to drain
5. Secure the cap back into place

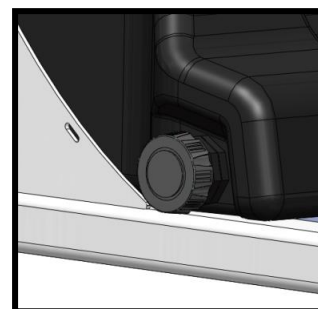

Operation

Initial Startup

When starting the sprayer for the first time conduct a trial run using water to become familiar with the operation of the controls and to check that all systems are functioning correctly without any leakage.

When filling the tank ensure that the basket strainer is in place and clean. Close the lid securely after filling.

Filter

The suction filter is fitted with a stop valve which closes automatically when the valve cap is screwed off. This allows the filter cover to be unscrewed and the element to be removed for cleaning while there is fluid in the tank.

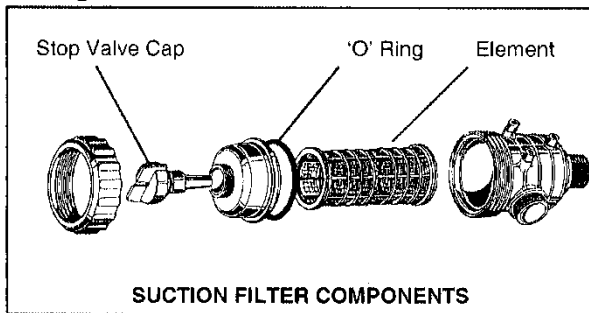

When the sprayer is operating, the valve must be fully screwed in to open the stop valve and allow fluid to pass through the filter. Directional arrows are moulded into the valve cap to show the opening and closing operation.

Control Valve Operation

Various types of control units are fitted to Silvan linkage sprayers - refer to the following pages for the operating details for each type - but the general operating information below is common to all sprayers.

Before engaging the PTO, the bypass control should be moved to the bypass position and the outlet valves should be closed, using either the individual valve levers or the single lever depending upon control type.

With electric valve controls the master valve should be off and the section valves off.

Engage the PTO slowly and allow the sprayer to run in bypass mode. Once the pump is primed increase the tractor speed to 540 PTO rpm.

The bypass lever can then be moved to the operating or pressure position and the pressure can be adjusted by turning the regulator knob and observing the reading on the gauge.

Open the outlet valves that are connected to the boom or other spraying device to start spraying.

Under most boom spraying conditions, the PTO speed can be reduced (minimum 400 PTO rpm) and the pump will still provide sufficient flow to suit the particular application rate being used.

This will save fuel and unnecessary wear on the tractor and sprayer components.

The selection of either the by-pass or pressure mode of operation is controlled by the rotary lever "A" - refer diagrams. Moving the lever clockwise through its full travel selects by-pass, which reduces the pump's operating pressure by allowing liquid to bypass the pressure regulator. Note, this operation does not fully shut-off the flow to the individual outlet taps. Moving the lever full anti-clockwise re-directs pressurised fluid to the outlets.

System pressure is regulated by turning the red (or on some valves black) knob "B" and observing the reading on the pressure gauge. Turning the knob clockwise increases the pressure and turning anti-clockwise decreases pressure.

Fluid is directed to the boom lines or other spraying devices by the outlet valves "C" which may be operated individually. The outlet valves of the two way control are open when the levers is in line with the direction of flow and closed when they are across the direction of flow. The outlet valves of the three way control are open when the levers are vertically down and closed when they are vertically up. Refer diagrams.

If you wish to stop spraying but leave the tractor PTO running, close the outlet valves "C" and move the by-pass lever "A" to bypass mode.

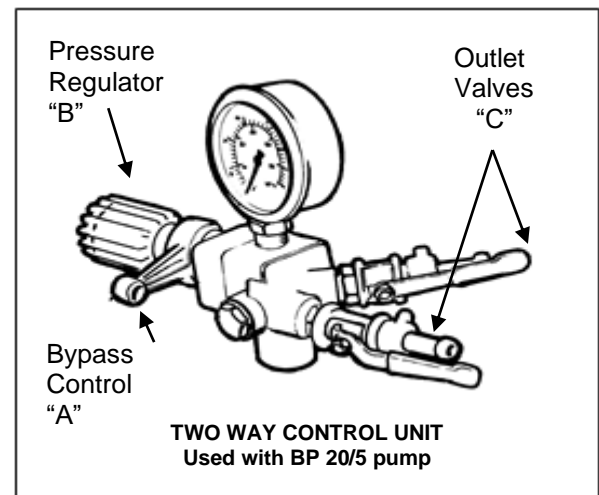

Operation

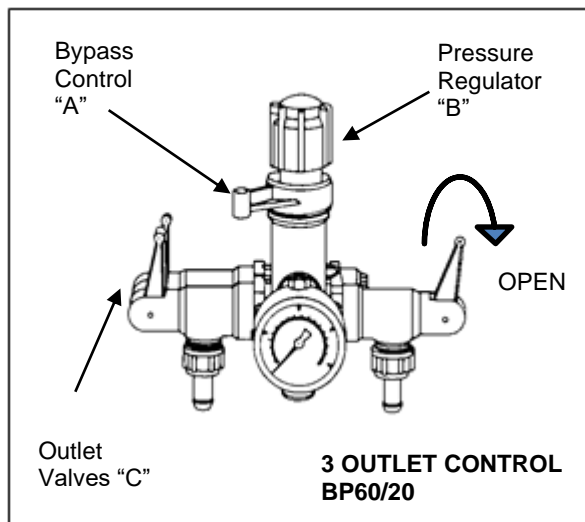

Four Outlet Single Lever Control Unit

Operation of by-pass control "A" and pressure regulator "B" is the same as that of the two and three outlet controls previously described.

Fluid is directed to the boom lines or other spraying devices by four outlet valves which may be operated individually or as a group. The individual valves are open when levers "C" are vertically down and closed when vertically up. Raising the single lever "D" and swinging it over to the other side of the valve opens the flow to all valves and swinging it back closes the flow.

Once the required outlets have been selected using the individual valves, spraying may be started and stopped by using the single lever. If you wish to stop spraying but leave the tractor PTO running, close the single lever and move the by-pass lever to by-pass mode.

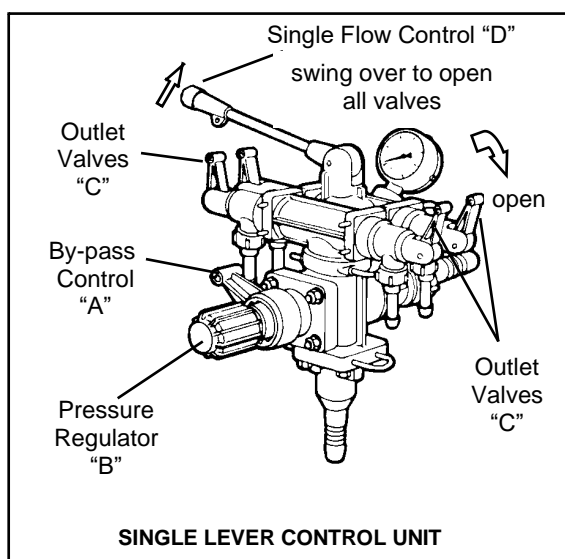

Electric Valve Controls

Refer to the instruction manual supplied with the unit if your sprayer has electric valve controls.

Spray Booms

A variety of booms may be used with Silvan linkage sprayers depending upon the model and field application. All have stainless steel spray lines fitted with non-drip air induction fan jet nozzles. Booms are part of the standard equipment on some models or in other cases they may be installed by the dealer.

On all types of boom, the setting of the correct operating height is most important to achieve a uniform spraying pattern. This needs to be at a height above the target which will achieve 50% overlap of the spray from adjacent nozzles - refer Calibration section of this manual.

Always ensure that no bystanders are close to the boom when it is unfolded and that it will not foul on any other objects.

Field Boom

For transport, the boom is folded horizontally by swinging the outer arms rearwards through 180° until against the fixed centre section, where they are retained by the action of the hinge springs. The arms are simply folded outwards to the spraying position when required.

The rear uprights of the sprayer frame include a series of holes to enable the boom to be attached at a height suitable for the tractor size and spraying application. Final spraying height is regulated by use of the tractor linkage control.

Devil Boom

The boom is folded hydraulically by two independent rams using two sets of tractor remotes.

Height adjustment can be achieved by two different methods either by using the same method as for the Field Boom or an optional hydraulic lift kit is available.

Foam Marker

Refer to the Foam Marker Operator's Manual for installation and operating procedures relevant to the foam marker.

Operation

Hose Reel and Spraygun

To operate the spraygun prime the pump as per normal then open the relevant control lever, set to the desired pressure (max 20 Bar). Unroll the amount of hose required to reach the area to be sprayed. Depress the trigger on the spraygun to spray.

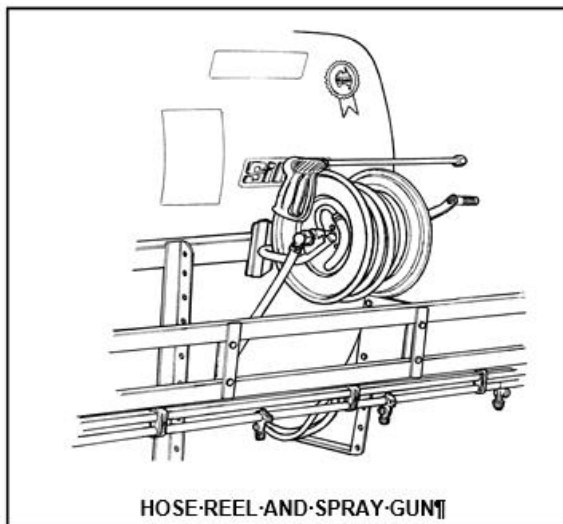

Starting the Sprayer

Engage the PTO slowly and allow the sprayer to run in by-pass mode. Once the pump is primed, increase the PTO speed to 540 rpm and turn the bypass control to the pressure setting.

The pressure can then be regulated by turning the regulator knob and observing the reading on the gauge.

The pumps are designed to operate up to a maximum pressure of 20 bar (290 psi) for BP125/20, BP75/20 & BP60/20 and 15 bar (218psi) for BP20/15. The pressure range used for boom spraying will usually be between 1 and 4 Bar depending upon the application rate and other factors - refer to the Calibration section of this manual.

Open the outlet valves that are connected to the boom or other spraying device to start spraying.

Adding Chemicals



Before adding chemicals read and follow the chemical manufacturer's instructions and wear the recommended personal protective clothing.

Before adding any chemicals fill the tank to at least 1/3 level with water. With the tractor PTO running at no less than 400 PTO rpm turn the outlet valves OFF and the bypass control to

BYPASS for maximum tank agitation. Pour chemicals into the tank through the basket filter then complete filling the tank with water.

Shutdown

After using chemicals in the sprayer flush the tank and pump by running clean water for a few minutes. If there is a risk of freezing run the pump dry for 2 to 3 minutes to insure all liquid is removed.

Sprayer Calibration

When to Spray

Results will be best when the wind speed is low; temperature is low and relative humidity high. An ideal time is at sun up when these conditions are most likely to apply.

Field Patterns

For overall coverage, spray two swaths around the outer perimeter of the field to establish a wide headland on which to turn. Make subsequent passes across the field following the direction of drilling. Turn the sprayer on and off as the boom passes over the headland. Spraying into the established headland will only result in chemical wastage and overdosing.

Droplet Size

Although more research is needed to define which is the optimum droplet size collected by particular targets, certain generalizations can be made. The trend with herbicides has been to apply large droplets (250 microns) to reduce the risk of drift but smaller droplets are often the most effective as shown by the following table.

DROPLET SIZE	COMMENTS
Large (above 300 microns)	Poor coverage and penetration. Stripping or uneven deposit. Minimal drift
Medium (150 - 300 microns)	Coverage, deposit and penetration fair. Some drift.
Small (below 150 microns)	Good coverage and penetration. Uniform application. Drift increased.

In general, the following factors can be varied to change droplet size.

- Reducing pressure increases droplet size.
- Reducing the nozzle fan angle (from 110° to 80°) increases droplet size.
- For an equivalent pressure and fan angle a larger size nozzle produces larger droplets.

Silvan spray booms are fitted as standard with size 02 (Yellow) air induced nozzles. These nozzles produce larger air filled droplets than the traditional flat fan nozzles to aid in drift reduction.

Nozzle Height and Spacing

To achieve a uniform spray pattern without gaps, the output from adjacent nozzles should overlap by 50% at the point of contact with the surface being sprayed.

Nozzles on Silvan booms are spaced at 50 cm intervals with caps offset 5° to the boom axis to avoid interference between adjacent spray fans.

The correct spray boom height to achieve 50% overlap is 40 cm for 110° nozzles and 60 cm for 80° but a variation in the order of 5 to 8 cm can be accommodated without noticeable effect. The height referred to is the distance above the target which may be either the vegetation or the ground surface depending upon the operation.

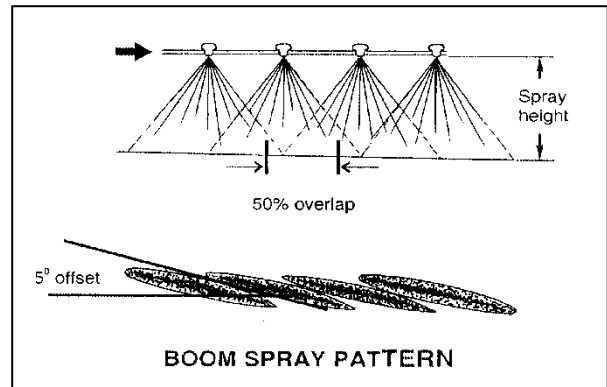

Application Rate

The application rate depends on the following:

- Speed of travel - increasing speed reduces application rate and vice versa.
- Operating pressure - increasing pressure increases application rate and vice versa.
- Nozzle size - increasing the nozzle size increases the application rate.

Ground Speed

The ground speed read out on modern tractors should be sufficiently accurate for spraying but if in doubt check it by the following method.

Measure and mark a distance of 100 metres. Fill the sprayer with water and engage the PTO to simulate normal spraying conditions. Approach the starting mark at the required spraying speed and accurately measure the time in seconds to reach the finishing mark. The ground speed can be calculated as follows.

$$\text{Speed (km/hr)} = \frac{360}{\text{Time in seconds for 100 m}}$$

Spray Pattern and Nozzle Uniformity

The overlap pattern of the boom, the spray pattern of individual nozzles and the uniformity of nozzle output can be tested in the following manner. Always keep one new nozzle aside from each set to use as comparator for this test.

1. Install the comparator nozzle, fill the sprayer tank with clean water and operate the boom at spraying pressure whilst stationary.

Sprayer Calibration

2. Examine the spray pattern from each nozzle against a dark background. Replace any that show streaks or signs of blockage.
3. Compare individual nozzle outputs by placing a container of equal size, such as the Silvan calibrated measuring jug, under each nozzle and run the sprayer for one minute. The water level in each container should be the same. Replace any nozzle giving more than 10% greater output than the comparator. Once several nozzles are worn to this extent it is good practice to replace the entire set.
4. Set the boom at the appropriate height for the nozzle angle, ie. 60 cm for 80° and 40 cm for 110°. Run the sprayer and check that the patterns from adjacent nozzles overlap as shown in the diagram on the previous page.
5. Remove and store the comparator nozzle.

Verifying the Calibration

After making the above tests to ensure pattern and output uniformity are correct, repeat the procedure at the recommended spraying pressure to compare the actual nozzle output with that shown on the nozzle selection charts. This may be done either as a test on an individual nozzle or the full boom.

a) Nozzle Test

Measure the fluid in litres, collected from one nozzle during one minute. The amount should agree with the flow rate shown in the Nozzle Selection Chart on the following pages, for the particular type and size fitted.

If the volume collected is too low the operating pressure may be increased and the test repeated, alternatively if the volume is too high the pressure can be lowered.

b) Boom Test

1. Partly fill the sprayer tank with water and mark the level or refer to the sight gauge.
2. Run the sprayer at 3.0 Bar for several minutes with all boom sections operating and measure the time carefully.
3. Refill the sprayer tank to the mark using a measuring jug and record the amount added.
4. The average output for one nozzle in l/min can be calculated as follows. It should agree with the flow rate shown at 3.0 Bar in the nozzle selection chart, for the particular type and size fitted.

$$\text{Nozzle output} = \frac{\text{Litres used}}{\text{No. nozzles} \times \text{No. minutes}}$$

5. If the nozzle output is lower than shown in the chart the pressure may be increased and the test repeated or, if more than shown, the pressure may be reduced.

Nozzle Care and Maintenance

Nozzles are one of the most critical components in the spraying system and yet are often the most neglected. Worn or damaged nozzles result in over application of expensive chemicals, crop damage and environmental contamination.

They should be examined and checked regularly by the method shown above. Replace nozzles which are not within 10% of the datum.

Always keep a quantity of spare nozzles with the sprayer for immediate replacement in the field when necessary.

Never attempt to clear a nozzle by blowing through by mouth and never remove stubborn deposits with a pin, wire or sharp instrument.

Blocked nozzles should be soaked in clean, warm water with a mild detergent added and carefully cleaned only with a soft brush or airline.

A new nozzle should be kept as a testing comparator and it is recommended that all nozzles are renewed once a year or at the first signs of deterioration, whichever occurs first.

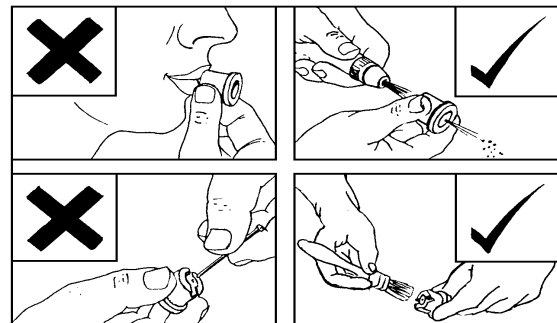

Sprayer Calibration

Nozzle Selection

Refer to the chemical manufacturer's information to determine the recommended application rate in litres per hectare (l/ha) for your particular situation. Then determine the speed in kilometres per hour (km/hr) at which you intend to spray, taking into consideration the ground conditions of the area to be sprayed.

Using the calibration chart below, select the most suitable nozzle to use at the normal recommended pressure of 3.0 Bar. The leading digits in the nozzle number indicate whether it is an 80° or 110° fan angle and the last two digits

refer to the size of the opening. Nozzles are ISO colour coded for easy identification.

All Silvan booms are fitted with size 02 (Yellow) 110° air induced nozzles suitable for a pressure range from 1.0 to 6.0 Bar. The chart below applies to ISO colour code nozzles.

For sprayers fitted with a Vineyard or Olive boom refer to the calibrating chart supplied with the boom. If necessary obtain this information from your Silvan dealer.

Examples of how to use the charts are given on the next page.



SPRAYER CALIBRATION CHART

1 BAR = 14.5 PSI

NOZZLE SPACING = 50cm

ISO STANDARD NOZZLE OUTPUT CHART FOR 80°/110° NOZZLES

ISO COLOUR CODE	LIQUID PRESSURE (BAR)	FLOW RATE L/MIN.	APPLICATION RATE: LITRES PER HECTARE.													
			6	8	10	12	14	16	18	20	22	24	26	28	30	
FAN TIP ORANGE 80-01 110-01 100 MESH	2.0	0.33	65	49	39	33	28	24	22	20	18	16	15	14	13	
	2.5	0.37	73	55	44	37	31	27	24	22	20	18	17	16	15	
	3.0	0.40	80	60	48	40	34	30	27	24	22	20	18	17	16	
	3.5	0.43	86	65	52	43	37	32	29	26	23	22	20	18	17	
	4.0	0.46	92	69	55	46	39	35	31	28	25	23	21	20	18	
FAN TIP GREEN 80-015 110-015 100 MESH	2.0	0.49	98	74	59	49	42	37	33	29	27	25	23	21	20	
	2.5	0.55	110	82	66	55	47	41	37	33	30	27	25	23	22	
	3.0	0.60	120	90	72	60	51	45	40	36	33	30	28	26	24	
	3.5	0.65	130	97	78	65	56	49	43	39	35	32	30	28	26	
	4.0	0.69	139	104	83	69	59	52	46	42	38	35	32	30	28	
FAN TIP YELLOW 80-02 110-02 50 MESH	2.0	0.65	131	98	78	65	56	49	44	39	36	33	30	28	26	
	2.5	0.73	146	110	88	73	63	55	49	44	40	37	34	31	29	
	3.0	0.80	160	120	96	80	69	60	53	48	44	40	37	34	32	
	3.5	0.86	173	130	104	86	74	65	58	52	47	43	40	37	35	
	4.0	0.92	185	139	111	92	79	69	62	55	50	46	43	40	37	
FAN TIP BLUE 80-03 110-03 50 MESH	2.0	0.98	196	147	118	98	84	74	65	59	53	49	45	42	39	
	2.5	1.10	219	164	131	110	94	82	73	66	60	55	51	47	44	
	3.0	1.20	240	180	144	120	103	90	80	72	65	60	55	51	48	
	3.5	1.30	259	194	156	130	111	97	86	78	71	65	60	56	52	
	4.0	1.39	277	208	166	139	119	104	92	83	76	69	64	59	55	
FAN TIP RED 80-04 110-04 50 MESH	2.0	1.31	261	196	157	131	112	98	87	78	71	65	60	56	52	
	2.5	1.46	292	219	175	146	125	110	97	88	80	73	67	63	58	
	3.0	1.60	320	240	192	160	137	120	107	96	87	80	74	69	64	
	3.5	1.73	346	259	207	173	148	130	115	104	94	86	80	74	69	
	4.0	1.85	369	277	222	185	158	139	123	111	101	92	85	79	74	
FAN TIP BROWN 80-05 110-05 50 MESH	2.0	1.63	326	245	196	163	140	122	109	98	89	82	75	70	65	
	2.5	1.82	364	273	218	182	156	137	121	109	99	91	84	78	73	
	3.0	2.00	400	300	240	200	171	150	133	120	109	100	92	86	80	
	3.5	2.16	432	324	259	216	185	162	144	130	118	108	100	93	86	
	4.0	2.31	462	346	277	231	198	173	154	139	126	115	107	99	92	
FAN TIP GREY 80-06 110-06 50 MESH	2.0	1.96	392	294	235	196	168	147	131	118	107	98	90	84	78	
	2.5	2.19	438	329	263	219	188	164	146	131	120	110	101	94	88	
	3.0	2.40	480	360	288	240	206	180	160	144	131	120	111	103	96	
	3.5	2.59	518	389	311	259	222	194	173	156	141	130	120	111	104	
	4.0	2.77	554	416	333	277	238	208	185	166	151	139	128	119	111	
FAN TIP WHITE 80-08 110-08 50 MESH	2.0	2.61	522	392	313	261	224	196	174	157	142	131	120	112	104	
	2.5	2.92	584	438	350	292	250	219	195	175	159	146	135	125	117	
	3.0	3.20	640	480	384	320	274	240	213	192	175	160	148	137	128	
	3.5	3.46	692	519	415	346	297	260	231	208	189	173	160	148	138	
	4.0	3.70	740	555	444	370	317	278	247	222	202	185	171	159	148	

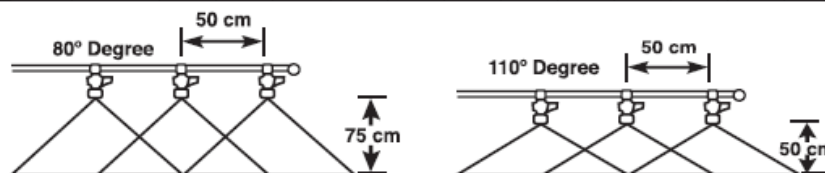

**CAUTION: ALWAYS MANUALLY CALIBRATE THE SPRAYER TO VERIFY APPLICATION RATE
ALWAYS REFER TO CHEMICAL LABEL FOR DROPLET SIZE REGULATIONS**

Sprayer Calibration

Using the Calibration Charts

Example: Required Application rate = 100 l/ha at approximately 10 km/hr

From the chart a rate of 96 l/ha can be achieved at a ground speed of 10 km/hr using 3.0 Bar pressure with a 11002 Yellow nozzle - refer to the nozzle selection chart on the previous page.

If the exact application rate does not appear in the chart it can be achieved by slightly adjusting the speed or pressure. For example, if a rate of 100 l/ha is required rather than 96 l/ha, it can be achieved with the same yellow nozzles by reducing the speed to 9.5 km/hr or increasing pressure to approximately 3.2 Bar.

Alternatively, the same rate of 100 l/ha could also be achieved with a larger nozzle and faster operating speed. By referring to the nozzle chart on the previous page it can be seen that a 11003 Blue nozzle will give this rate at a little under 14 km/hr and 3.0 Bar (the rate shown on the chart at 14 km/hr is 103 l/ha).

It can thus be seen that a variety of choices exist for most application rates and the final selection of nozzle, speed and pressure will depend upon the factors which best suit your conditions.

Always perform a calibration check to confirm your nozzle selection, as described on page 14.

Maintenance

Before carrying out any maintenance

Disconnect the tractor PTO and ensure the sprayer is adequately supported before performing any operation on the sprayer.

AFTER EVERY TANK

Oil Condition

The condition of oil should be frequently checked (eg. each time the tank is filled) as it affects the operation of the pump and the condition and life of the diaphragms. If the oil becomes white (water present in oil), it may be a symptom of failure of one or more diaphragms. It is necessary to **stop work** and inspect the condition of the diaphragms. If broken, it is necessary to replace the complete set.

Continued use with water in the oil will cause serious damage to internal parts of the pump.

If it is not possible to replace broken diaphragms within one day of failure, empty the crankcase of water and pour in oil to stop rust from forming on the internal components.

Oil Level

When the pump is stationary, the oil level must correspond to the reference indicator found on the oil sight glass or oil level cap depending on the type of pump. The oil level may vary when the diaphragm pump is working: As the pump is started, the oil level will initially drop and then return to functioning level when the liquid begins to pump.

During operation, pay attention to any drop in the oil level:

- If this happens during the first few hours of operation it is normal and it is sufficient to top up with SAE 20W/40 type oil.
- If this happens after many hours of operation and continues after 1 or 2 top ups, it is a symptom of diaphragm swelling caused by restricted suction (dirty filter, collapsed suction hose or chemical attack to diaphragm). In this case check the filter and suction system and/or refer to your Silvan dealer to check the diaphragm.

Filters

Always clean the suction filter before each tank refill (especially if powder based products are used) and at the end of the day. Close the stop valve by pushing the cap in and turning it in the direction indicated on the cap nut, then unscrew the filter cover to remove the filter element - refer diagram in Operation section. Ensure the 'O' ring is in good condition when refitting.

Re-assemble in reverse order

Check and if necessary clean the basket strainer under the tank lid before each fill.

DAILY MAINTENANCE

General

During the first few days of operation, before starting each day check that all hardware is tight and inspect the unit for leaks while running and tighten all hose clamps.

PTO Shaft

For safety considerations, it is **very important** to inspect the condition of the PTO guard and chains daily and to maintain as necessary.

Grease the PTO shaft and guard with multi-purpose grease at the time intervals shown below. This is the amount of lubrication recommended for normal operation. More frequent inspection and lubrication may be needed under very dusty conditions.

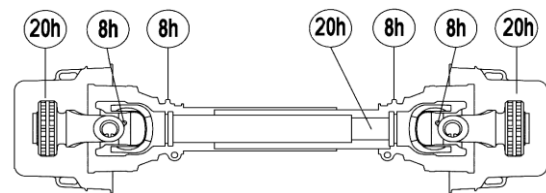

Remove the shaft from the tractor and sprayer, slide the PTO shaft apart, clean the telescopic tubes and female ends with kerosene and apply multi-purpose grease to the sliding surfaces, then reassemble. This is most important in dusty conditions.

Maintenance

Filters

Clean all filters daily. More frequent cleaning may be necessary depending upon circumstances such as water quality, chemicals used etc. The best method for cleaning filters is to wash them with a soft bristle brush. Check for any tears or holes and replace if damaged.

Pump Mounting

Check daily, especially when there is vibration during use that the pump mounting bolts on the machine frame are tight and if necessary re-tighten.

Tank and Spray Lines

At the end of each day run clean water through the pump and lines to purge them of chemicals. Rinse out the tank to remove powdered material.

Never leave chemicals in the tank that may settle to the bottom, harden and break into lumps as this may block the suction filter.

Freezing Conditions

If frosts or freezing conditions are likely to occur then drain all water from the pump to ensure the pump is not damaged by freezing water expanding inside the pump.

EVERY 50 HOURS

Diaphragm Pump

Check the inflation of the pressure accumulator, if fitted, according to Table A (in the operations section of this manual) especially if there are vibrations on the delivery hose and/or the pressure gauge.

Pressure Regulator

Grease rotating and sliding parts.

Plumbing

The suction system must be inspected to ensure:

1. There are no suction air leaks. Check for entry of air caused by:
 - entry of air caused by hose wear;
 - loose fittings;
 - worn joints;
2. There are no small leaks or drips on the suction side of the pump when it is stationary. If this occurs it means air will enter the pump when in operation.
3. There are no leaks around all hoses and fittings.

Hardware

Check all bolts are tight. Refer to Silvan Torque setting chart available from Silvan Technical Support Dept.

EVERY 300 HOURS

Diaphragm Pump

Every 300 hours (or more often if sandy or abrasive liquids are used) change the oil and the diaphragms in the pump and inspect the mechanical condition of the components. This must be carried out by an authorised Silvan dealer.

Pressure Regulator

Check the pressure adjustment valve.

PTO Shaft and Guard

Check the shaft and guard for wear and if necessary have it repaired by an authorized Silvan Dealer.

ANNUALLY

Diaphragm Pump

Check diaphragms and replace if necessary.
Replace the oil.

Pressure Regulator

Check and replace the inner diaphragm where required and check screws are tight.

Hardware

At the end of each season, generally inspect the sprayer for any signs of damage and check that all bolts are securely tightened.

Storage in cold areas

The pump is not frost proof therefore it is recommended that motor grade anti-freeze (diluted to the recommended proportions) be pumped through the system for 2 minutes. The system should then be drained by operating the pump for a further 2 minutes without taking up any liquid.

Troubleshooting

Pump does not prime

- No liquid in tank or not covering suction inlet.
- Suction filter blocked.
- Suction filter stop valve closed.
- Suction filter bowl loose or missing O-ring.
- Suction line loose allowing pump to suck air.
- Control lever not in by-pass position.
- Pump valve springs broken or valves worn.

Pump does not reach correct pressure

- Pump not operating at full 540 rpm.
- Suction filter blocked.
- Suction filter stop valve partly closed
- Pressure regulator not correctly adjusted
- Pressure regulator valve and seats worn.
- Pressure gauge faulty
- Pump diaphragms ruptured (pump oil grey or milky).
- Worn nozzles or capacity of nozzles greater than capacity of the pump.
- Worn pump inlet / outlet valves

Pump and hoses vibrating.

- Pump surge chamber pressure incorrectly adjusted or surge diaphragm ruptured.
- Air entering the suction line through loose or damaged fittings.
- Pump valves or valve springs worn or damaged.
- Worn nozzles or capacity of nozzles greater than capacity of the pump.
- Air trapped in filter or suction lines.

Water in oil (oil is a whitish grey colour)

- Broken diaphragms.

Pressure regulator valve vibrates

- Worn adjustment plate seat

Pressure regulator leaking water

- Loose screws
- Damaged diaphragm in regulator

Notes

Notes

Notes

SILVAN AUSTRALIA PTY. LTD.
ABN 48 099 851 144

AUSTRALIA (HEAD OFFICE)

68 Atlantic Drive
Keysborough
Victoria, 3173
Telephone: 1300 745 826
Fax: 1800 745 826

www.silvan.com.au

NEW ZEALAND

22 Sunshine Ave, Te Rapa
Hamilton, 3241
Telephone: 0508 745 826
Fax: (07) 849 6070

www.silvannz.co.nz

