



## ***Instruction Manual***

MANRP50-5 REV C 21/04/20

**QUAD BIKE 12V SPRAYER 50L & 70L  
RP50-P1, RP70-P1**



**SILVAN AUSTRALIA PTY. LTD.**

ABN 48 099 851 144

### ***VICTORIA (HEAD OFFICE)***

Telephone: +61 (03) 9215 2700

Fax: +61 (03) 9215 2701

[www.silvan.com.au](http://www.silvan.com.au)

### ***NEW ZEALAND***

Hamilton, New Zealand

Telephone: +64 (07) 8496 033

Fax: +64 (07) 8496070

[www.silvannz.co.nz](http://www.silvannz.co.nz)

## Silvan Warranty

**Our goods come with guarantees that cannot be excluded under the Australian Consumer Law. You are entitled to a replacement or refund for a major failure and for compensation for any other reasonably foreseeable loss or damage. You are also entitled to have the goods repaired or replaced if the goods fail to be of acceptable quality and the failure does not amount to a major failure.**

We warrant our goods to be free from defects in materials and workmanship for the warranty period of 12 months from the date the product is delivered to the consumer.

Silvan warrants its authorised Dealer, who in turn warrants the original purchaser (consumer) of each new Silvan product that it will repair or replace the product, or, pay the cost of repair or replacement, as determined by Silvan without charge for labour or any defective or malfunctioning parts in accordance with the warranty limitations below.

This Warranty is in addition to any other rights and remedies available to consumers under the law

### This Warranty Covers

Only conditions resulting directly from defects in workmanship or material under normal use and service.

### Warranty Exclusions

The Warranty does not cover:

- Conditions resulting from misuse, use of incompatible chemicals, exceeding machine specifications including overloading, impact damage, negligence, accidental damage or failure to perform recommended maintenance services as specified in the Owner/Operator Manual applicable to the product.
- Damage caused by continued use of a product after initial failure
- Any product which has been repaired by other than an authorised Silvan service outlet in a way which, in the sole and absolute judgment of Silvan, adversely affect its performance or reliability.
- The replacement of maintenance items such as diaphragms, batteries, V belts and ground engaging components, etc.

### How To Claim Warranty

Return the goods to the place of purchase at your cost and within the warranty period along with evidence of the purchase date. If the original supplier cannot be contacted, then contact Silvan as below and we can direct you on how to proceed with your warranty claim.

### How Your Claim Will Be Managed

The repair of a defective product qualifying under this warranty will be performed by any authorised Silvan service outlet within a reasonable time following the delivery of the product, at the cost of the owner, to the service outlet's place of business. The product will be repaired or replaced depending on the extent of the problem at the discretion of Silvan and the Silvan dealer.

# Safety Instructions



Before attempting to operate or install the sprayer carefully read and take note of the following safety warnings.

Failure to comply with these warnings may result in serious injury or death.

**Warning!** This sprayer is designed and manufactured solely for the purpose of applying agricultural chemicals to plants. Under no circumstances may it be used for any other purposes.

**Warning!** Prior to installing or using the sprayer all operators must have read and fully understood the contents of this instruction manual and the safety decal fitted to the sprayer.

**Warning!** Never allow an inadequately trained person to install or operate the sprayer.

**Warning!** When installing the sprayer on a vehicle do not exceed the vehicle manufacturer's specified safe load and carrying capacity when the sprayer tank is full. Refer also to the vehicle manufacturer's operating and safety instructions.

**Warning!** Exercise extreme care when operating in hilly or uneven terrain to ensure proper stability. Refer also to the vehicle manufacturer's operating and safety instructions

**Warning!** Stability may be affected by water surging inside the spray tank.

**Warning!** Refer to the chemical manufacturer's label for correct use and safe handling instructions of chemicals before filling or using the sprayer. Always wear the recommended safety clothing and equipment when handling chemicals and operating the sprayer. Ensure that all operators and associated personnel are familiar with the legal regulations and codes of practice that apply to the safe use, storage, and disposal of spray chemicals

**Warning!** Before carrying out maintenance work, wash the sprayer thoroughly to remove all toxic chemicals that may contaminate the sprayer. Wear appropriate safety clothing and equipment when carrying out maintenance.

**Warning!** Never point the spray gun at any person or any part of the human body.

The wording of the Safety decal is shown below. All operators must be made aware of the decal and follow its instructions.

The decal must be fitted to the machine at all times in the location shown. If the decal is missing or unreadable it should be replaced by ordering a new decal from your Silvan dealer under part number, DEC 48.



# Specifications



## GENERAL

The Silvan Rakpak is a compact portable sprayer. Whether you are a commercial grower, or hobby farmer, you will find many uses for this unit. The tank, pump and spray lance fittings are corrosion resistant and suitable for applying weedicides, herbicides, insecticides, fungicides, miticides, organic and green formulations.

It has been solely designed for mounting on four-wheel Quad Bikes. The Rakpak is designed for spot spraying but may be used in conjunction with a boom for boom spraying.

## SPECIFICATIONS

### **PUMP AND CONTROLS:**

Pakpump 2000 series, 12-volt DC electric pump. Open flow Capacity 5.3 L/minute or Maximum pressure 60psi.

On-Off power switch and an “on demand” pressure sensing switch.

Supplied with 3 metre power loom with alligator clamps for connection to 12-volt battery and a fuse holder on the positive lead fitted with automotive type 10-amp fuse.

The “On-Demand” pressure sensing switch will automatically start the pump when the spray gun trigger is pulled, and the pressure falls below 40psi. The automatic pressure switch will stop the pump when the spray gun trigger is released, and the pressure increases to 60psi.

**If the pump is subjected to rapid pulsation/cycling during normal operation it may reduce the life of the pressure switch.** Applications which exhibit rapid pulsation/cycling may have restrictions in the nozzle caused by dirt or may require a larger nozzle to minimize pulsation.

### **TANK:**

Translucent tank moulded from U.V. stabilized and impact resistant polyethylene.

135mm filler neck with screw on anti-spill breather lid.

Calibrated fill mark moulded into tank as well as recesses for locating tie down straps for transport.

### **FILTRATION:**

Wire mesh foot filter on suction line, removable for cleaning.

### **DELIVERY HOSE:**

6 metre length, 8 mm I.D.

### **SPRAY GUN:**

Spray gun with adjustable spray nozzle.

<b>DIMENSIONS</b>	50L	70L
Length	775mm	800mm
Width	850mm	850mm
Height	250mm	390mm
Weight (dry)	10kg	12kg
Nominal capacity	50L	70L

## FITTING TO A VEHICLE

The sprayer should be securely attached to the Quad bike. The transverse recesses moulded into the top of the tank can be used to positively locate the tie down straps, which should be firmly secured to approved attachment points on the ATV or other vehicle.

The sprayer should be mounted centrally and as near to the centre of gravity of the Quad bike as possible. It should not protrude to cause an obstruction. Refer to the manufacturer's instructions for appropriate load limits and fitting positions.

Never fill the spray tank to a capacity beyond the specified overall weight limit set by your vehicle manufacturer.

**Note: 1 litre of water = 1 kg.**

**Warning!** Do not exceed the the vehicle manufacturer's specified safe load and carrying capacity.

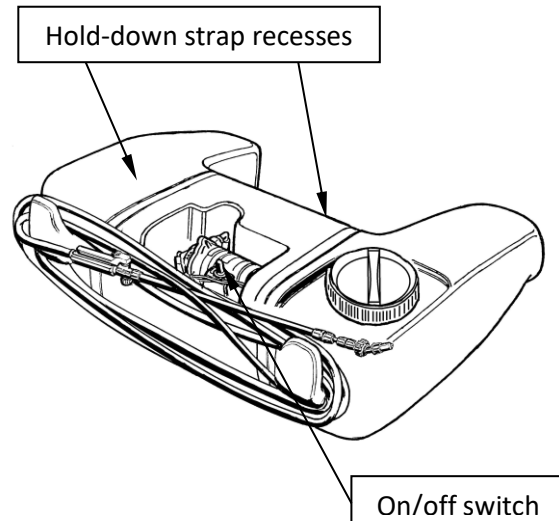

## CONNECTING TO 12 VOLT DC SUPPLY

The sprayer requires a 12-volt DC power source to operate the pump, such as the vehicle battery. The wiring loom is fitted with alligator clamps to facilitate connection to a normal vehicle battery. The red clamp should be connected to the positive terminal and the black clamp to the negative terminal.

If you need to extend the wiring loom use wire of the same gauge or thicker.

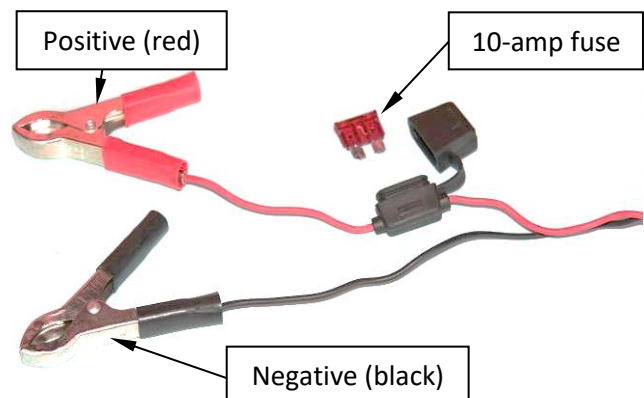

## SAFETY FUSE

The positive (brown) lead incorporates a 10-amp automotive type fuse in a rubberised holder. This protects the pump and vehicle electrical system from damage should a short circuit occur. If a fuse should blow determine the cause of the short circuit before replacing the fuse.

## ON/OFF SWITCH

The on/off switch on the top of the tank operates the pump. It should be switched off when the pump is not in use or when the tank is empty to prevent unnecessary drain of power and overheating and damage to the pump.

## CONNECT LANCE AND TRIGGER

For sprayer, there is a gasket which should fit between lance and trigger. The small side is positioned face to trigger.

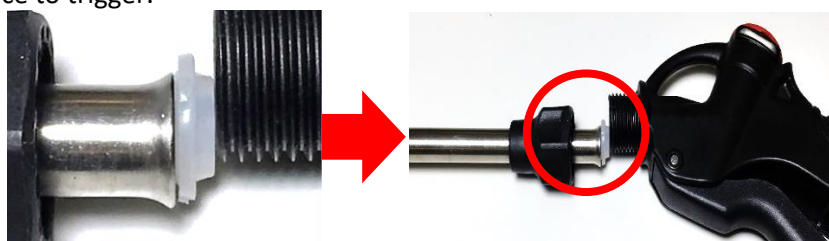



## SETUP AND TESTING

It is always recommended that you first test all spray equipment thoroughly with clean water. Silvan Rakpack's are supplied with an adjustable nozzle containing a large orifice, which when twisting the tip can allow for a greater flow of liquid. It is recommended that adjustable nozzle is used first and can be changed later if you require.

1. Be sure to wear safety equipment as recommended by the chemical manufacturer before adding chemical to the sprayer
2. Check the suction line foot filter is clean and undamaged (see Maintenance section).
3. Fill the tank with clean water.
4. With the 12-volt supply connected and the 6-meter spray hose and spray lance connected fit the adjustable nozzle or any large orifice nozzle you may wish to use.
5. Check all pipes, hoses, hose clamps and connections for leaks or damage.
6. Switch the pump ON.
7. Depress the spray lance trigger. The pump is self-priming and will start spraying within 30 seconds.
8. Check the hose connections for leaks, if any are found stop the pump and rectify the problem before continuing.
9. By twisting the tip of the nozzle to the coarsest droplet size, the restriction to flow is minimized and pump pulsation will not occur.
10. Slowly twist the tip of the nozzle from a coarse droplet size to a fine droplet to your preference. If the pump begins to pulsate/cycle you may require a different nozzle that is rated to allow for higher flow rates at your selected droplet size at approximately.
11. Once the nozzle is set the sprayer is ready to be utilized for spot spraying of chemical.
12. Chemical solution may now be added to the tank. Follow the mixing instructions and safety precautions provided by the chemical manufacturer. Before adding concentrated chemicals, partially fill the tank with water then add the chemical and complete filling with water. Wear all the safety equipment recommended by the chemical manufacturer before adding chemical to the sprayer and whilst conducting spraying operations

## PUMP HOSE ANCHOR

We have supplied a Plastic Hose Tie to protect the pump housing or hose fitting from possible damage caused when the hose is pulled tight or over stretched.

The hose can be tied against the switch bracket as shown in the diagram below without restricting the flow.

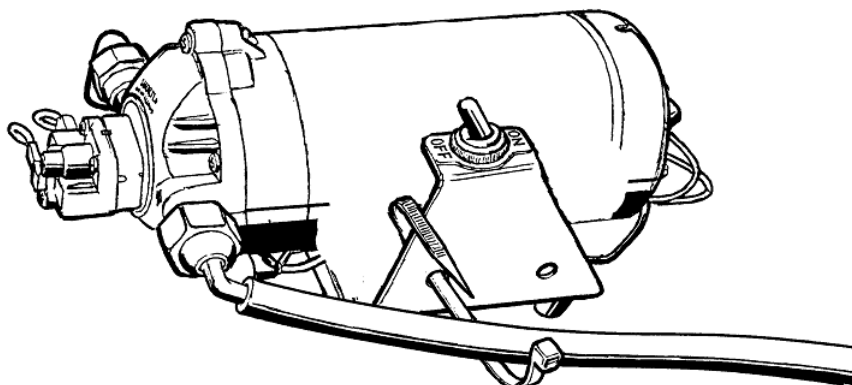

## Operation (cont.)



After spraying is completed, drain unused chemicals from the tank. Rinse the tank with clean water then operate the sprayer with clean water in the tank to clean out the pump, hose, and spray lance. Do not leave chemicals in the tank as they may settle and form solids that may block the filter.

If heavy frosts are experienced, run the sprayer until the pump and spray lines are dry. This will prevent water freezing in the pump or spray lines and damaging the sprayer.



Dispose of unused chemical and water used for rinsing in a manner that will not endanger people, animals, or the environment in accordance with local regulations and the handling and disposal information available from the Chemical manufacturer.

## Maintenance

After spraying rinse out the spray lines and tank with clean water

The foot filter should be checked and cleaned if necessary, each time the tank is filled. Appropriate protective equipment including gloves should be used whenever maintenance is carried out.

### **CLEANING THE FILTER**

To check the filter, remove the filler cap and hook the suction hose out with a bent piece of wire. To avoid chemical contamination do not put bare hands in the tank to remove the filter. Appropriate protective equipment including gloves should be used whenever maintenance is carried out. Clean the filter with a bristle brush, do not use a wire brush or sharp object as this may damage the mesh. The filter can be pulled from the suction hose if necessary, for cleaning. When reinstalling the filter in the tank press the suction hose into the recess to keep the filter on the bottom of the tank so that it will fully empty.